

Intelligent Voltage Detection Module

- Low voltage/NOT charging solid indicator output (*under 13.8v*)
- High voltage/over charging blinking indicator output (*over 14.8v*)
- Critical over voltage trigger output (*for relay*) (*over 15.5v*)
- Integrated diode board over-ride trigger
- Small compact design

- Powered by RISC processor
- Water-proof & shock-proof
- Digital operation for all types of indicator lamps
- Accurate monitoring for proper charging operation



Standard Installation

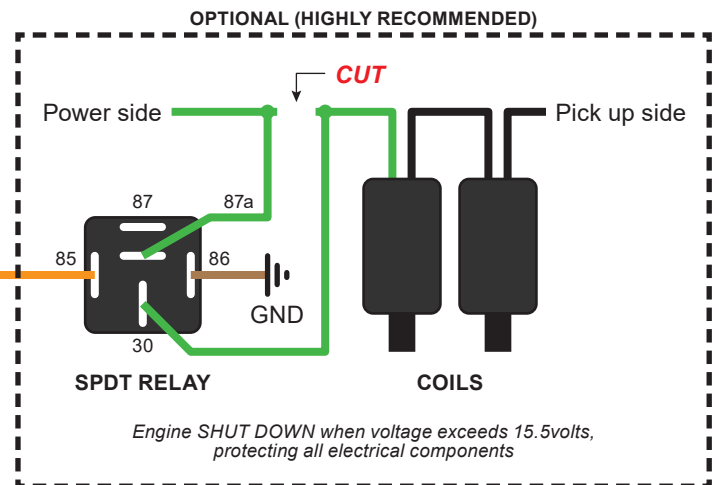
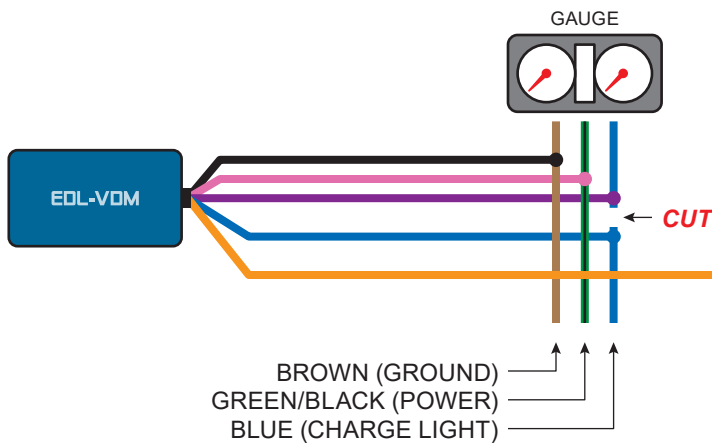

Custom Installation

